

Model L677E

Extruded Aluminum Louver • 6" Deep • 35° Drainable Baffle Blades • Combination Adjustable • Exhaust Only

STANDARD CONSTRUCTION

- FRAME:** .081" thk. (nominal) extruded aluminum, 6063-T52/T6 alloy. Channel type.
- BLADES:** Stationary blades are made from .081" thk. (nominal) extruded aluminum 6063-T52/T6 alloy. Operable blades are made from .032" thk. (nominal) formed aluminum. Blades are approximately 3½" on centers.
- LOUVER FACE:** Full width sill with head and blades contained within jambs.
- BEARINGS:** Oilite bronze, press fit into frame.
- SCREEN:** (When indicated, in a removable frame)
 - ½" flattened aluminum, .051" thk.,
 - or- 1¼" aluminum mesh insect screen, .011" dia.,
 - or- ½" sq. mesh intermediate double crimped aluminum wire, .063" dia.
- FINISH:** Mill.

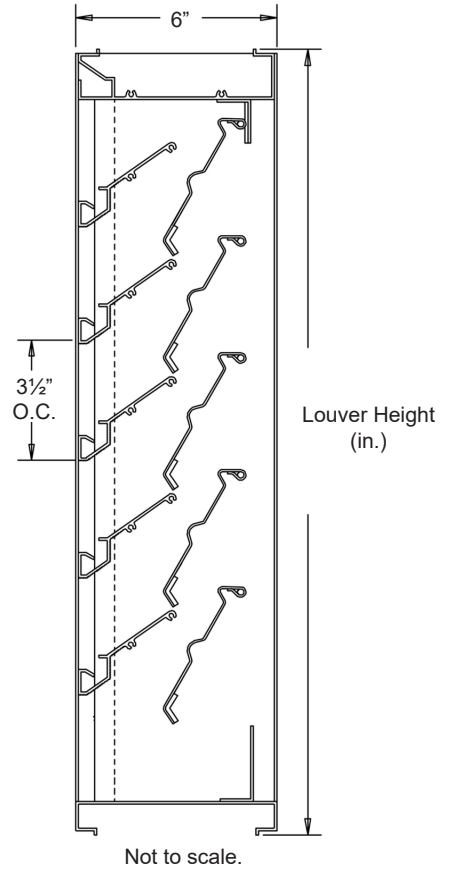

OPTIONS

- Finishes - Enamels, Epoxies, etc.
- Other screens available.
- Actuators - Electric, Pneumatic, Manual, etc.

NOTES

1. Nominal deductions will be made to the opening size given.
2. Approximate shipping weight is 5.3 lbs./sq.ft.

LOUVER SIZES

Min Panel	Max Single Panel
12"W x 12"H	48"W x 72"H

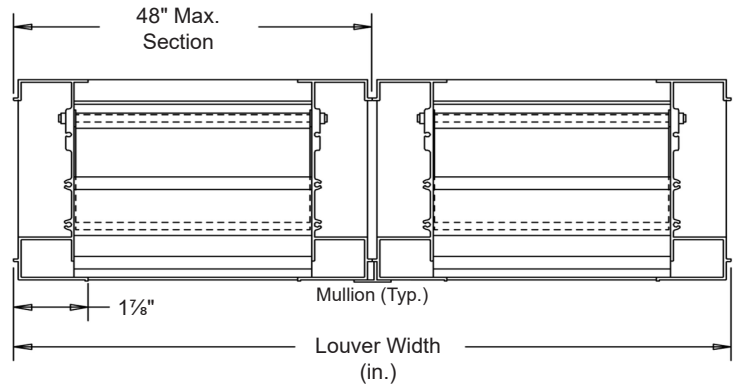
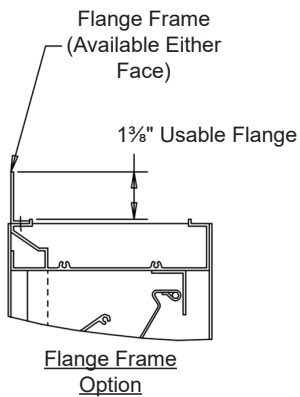
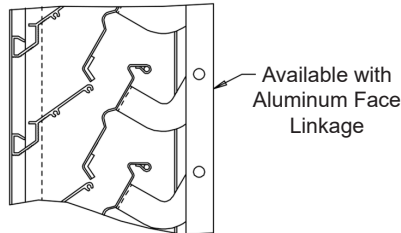

Item #	Qty	Width	Height	Width	Height	Mullion	Type	Location	Screens			
Arch. / Eng. :		Opening Size		Louver Size		EDR:		ECN:	Job:			
Contractor:												
Project:						Date:		DWN:		DWG:		

In the interest of product development, Louvers & Dampers reserves the right to make changes without notice.

www.louvers-dampers.com

450 Riverside Drive • Wyalusing PA, 18853 • Phone 570-746-1888 • Fax 570-746-9286



Model L677E

Extruded Aluminum Louver • 6" Deep • 35° Drainable Baffle Blades • Combination Adjustable • Exhaust Only

PERFORMANCE DATA

Pressure Drop: .19 in. w.g. (exhaust) without Face Linkage
.08 in. w.g. (exhaust) with Face Linkage fully open

Free Area: 8.18 sq.ft. = 51% for 48"W x 48"H sample tested in accordance with AMCA Standard 500-L.

Ratings do not include the effect of a screen.

Without Face Linkage

Louver installed per AMCA Standard 500-L Fig. 5.5
Pressure is corrected to .075 lb./cu.ft. air density.

Operational Pressures
Start to Open - .053 in. w.g.
Open - .182 in. w.g.

Pressure Drop

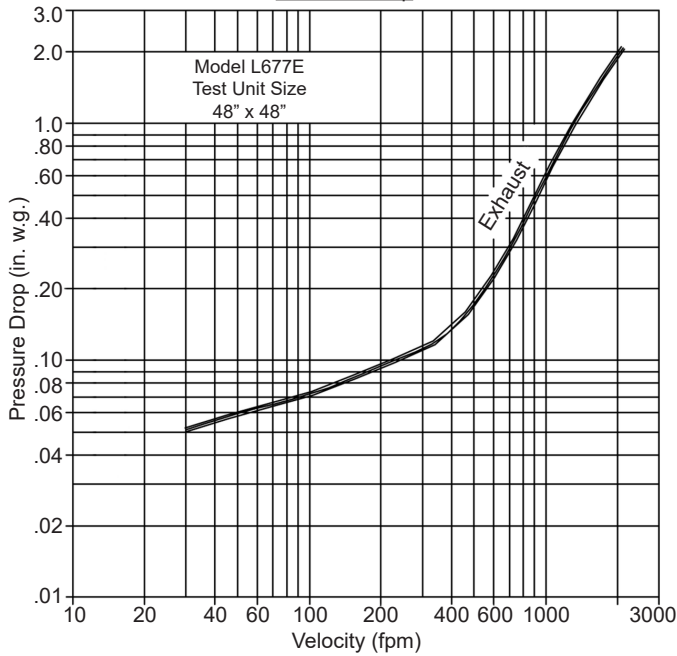

With Face Linkage

Louver installed per AMCA Standard 500-L Fig. 5.5 (Face mounted to plenum)
Pressure is corrected to .075 lb./cu.ft. air density.

Operational Pressures
Start to Open - .010 in. w.g.
Open - .073 in. w.g.

Pressure Drop

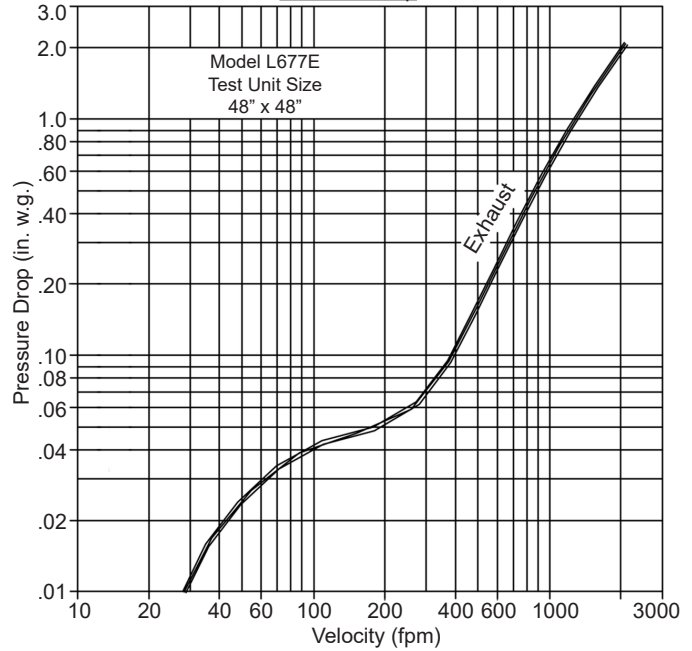

Exhaust air converted to .075 lb./cu.ft. air density.

Free Area (sq.ft)

		Width (in.)						
		12"	18"	24"	30"	36"	42"	48"
Height (in.)	12"	.25	.43	.61	.79	.97	1.15	1.33
	24"	.69	1.20	1.70	2.21	2.71	3.22	3.72
	36"	1.07	1.85	2.63	3.41	4.19	4.97	5.75
	48"	1.52	2.63	3.74	4.85	5.96	7.07	8.18
	60"	1.90	3.28	4.66	6.04	7.42	8.80	10.18
	72"	2.35	4.06	5.77	7.48	9.19	10.90	12.60

AMCA Registered Laboratory is a laboratory equipped and staged to conduct tests according to the appropriate AMCA test methods and which has been licensed as an AMCA Registered Laboratory.

